

Theory of Reconstruction

What are inside the gantry?

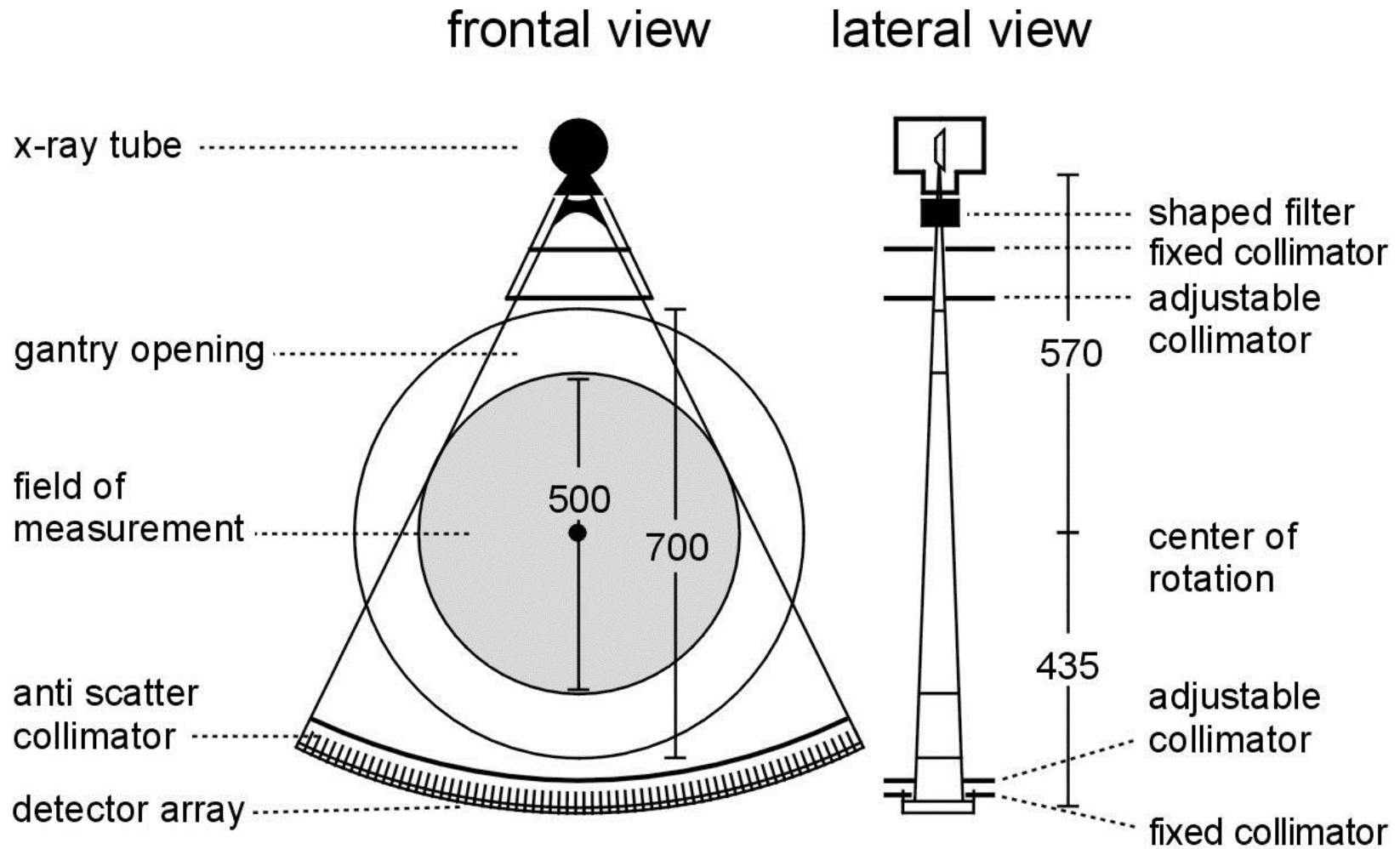

Schematic Representation of the Scanning Geometry of a CT System

X-ray

2 % attenuation change detectable in film

CT

0.2 % change in attenuation coefficient

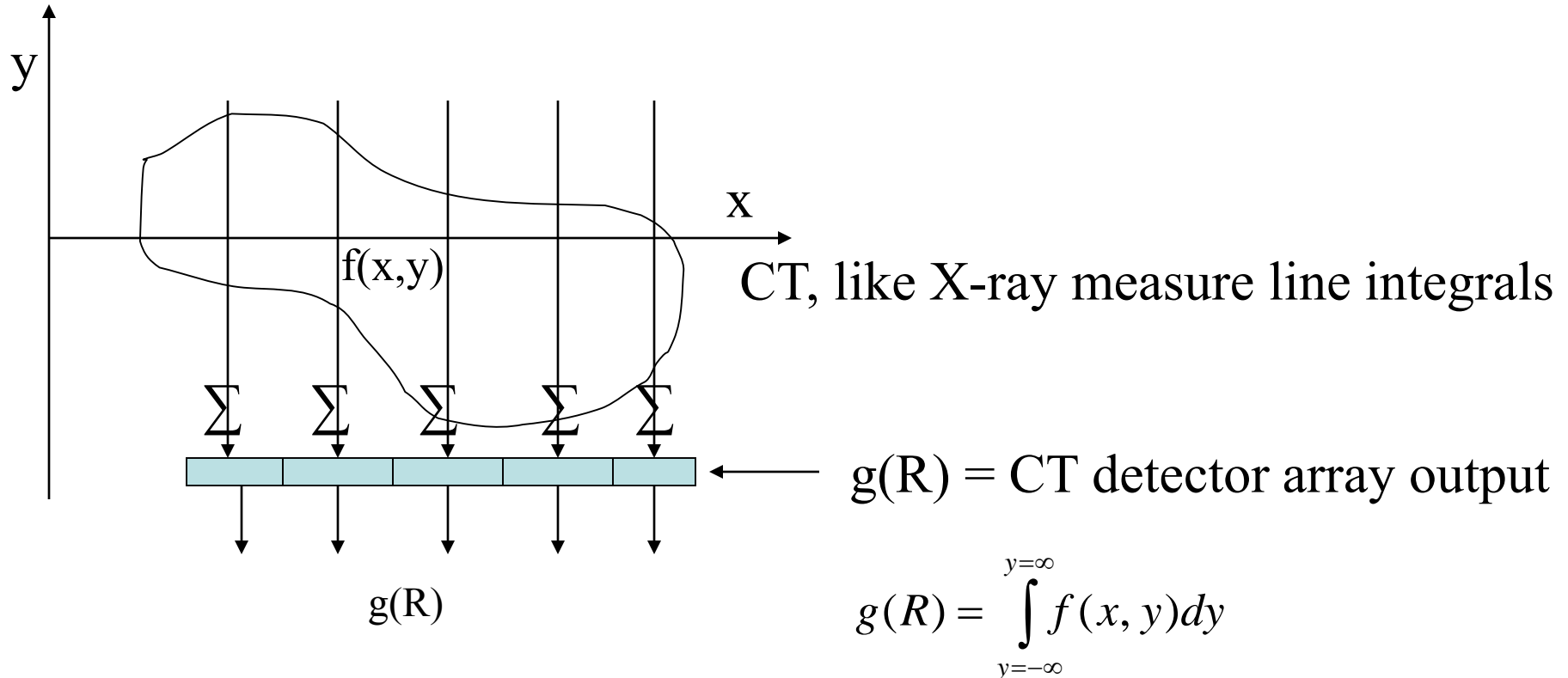

Direct Methods

Radon Transform 1917

Central Section Theorem - Bracewell

The transform of each projection forms a line, at that angle, in the 2D FT of $f(x,y)$

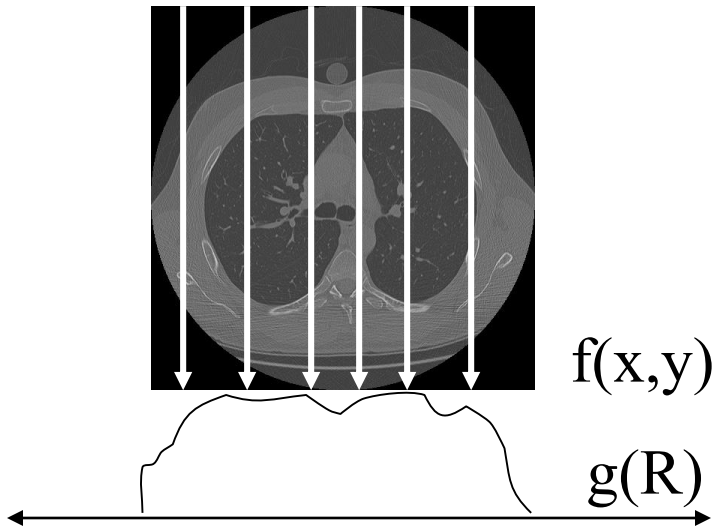

$$g(R) = \int f(x,y) dy$$

We will skip the Algebraic Reconstruction Technique

First, let's think of our experience on the meaning of $F(u,0)$ in the Fourier transform.

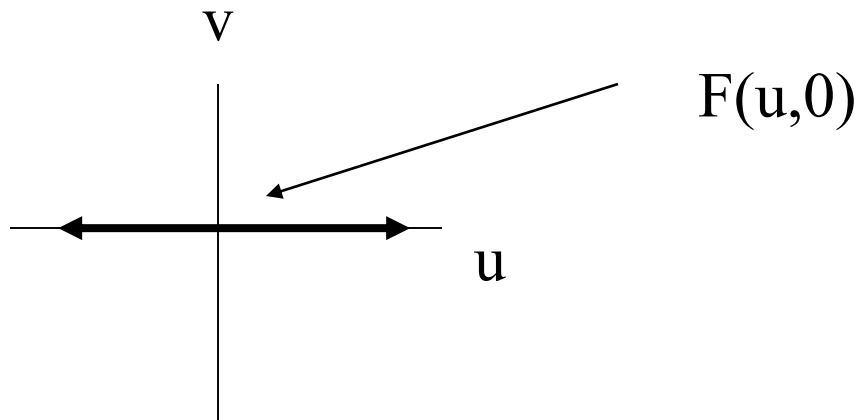

$$\{f(x,y)\} \Rightarrow F(u,v) = \iint f(x,y) e^{-i 2\pi (ux + vy)} dx dy$$

$$F(u,0) = \int \left[\int f(x,y) dy \right] e^{-i 2\pi ux} dx$$

So $F(u,0)$ is the Fourier transform of the projection formed from line integrals along the y direction.

Incident x-rays pass through the object $f(x,y)$ from upper left to lower right at the angle $90 + \theta$. For each point R , a different line integral describes the result on the function $g_\theta(R)$. $g_\theta(R)$ is measured by an array of detectors or a moving detector.

The thick line (in next slice) is described by

$$x \cos \theta + y \sin \theta = R$$

I have just drawn one thick line to show one line integral, but the diagram is general and pertains to any value of R .

Central Section Theorem

The 1D Fourier Transform of a projection at angle θ forms a line in the 2D Fourier space of the image at the same angle.

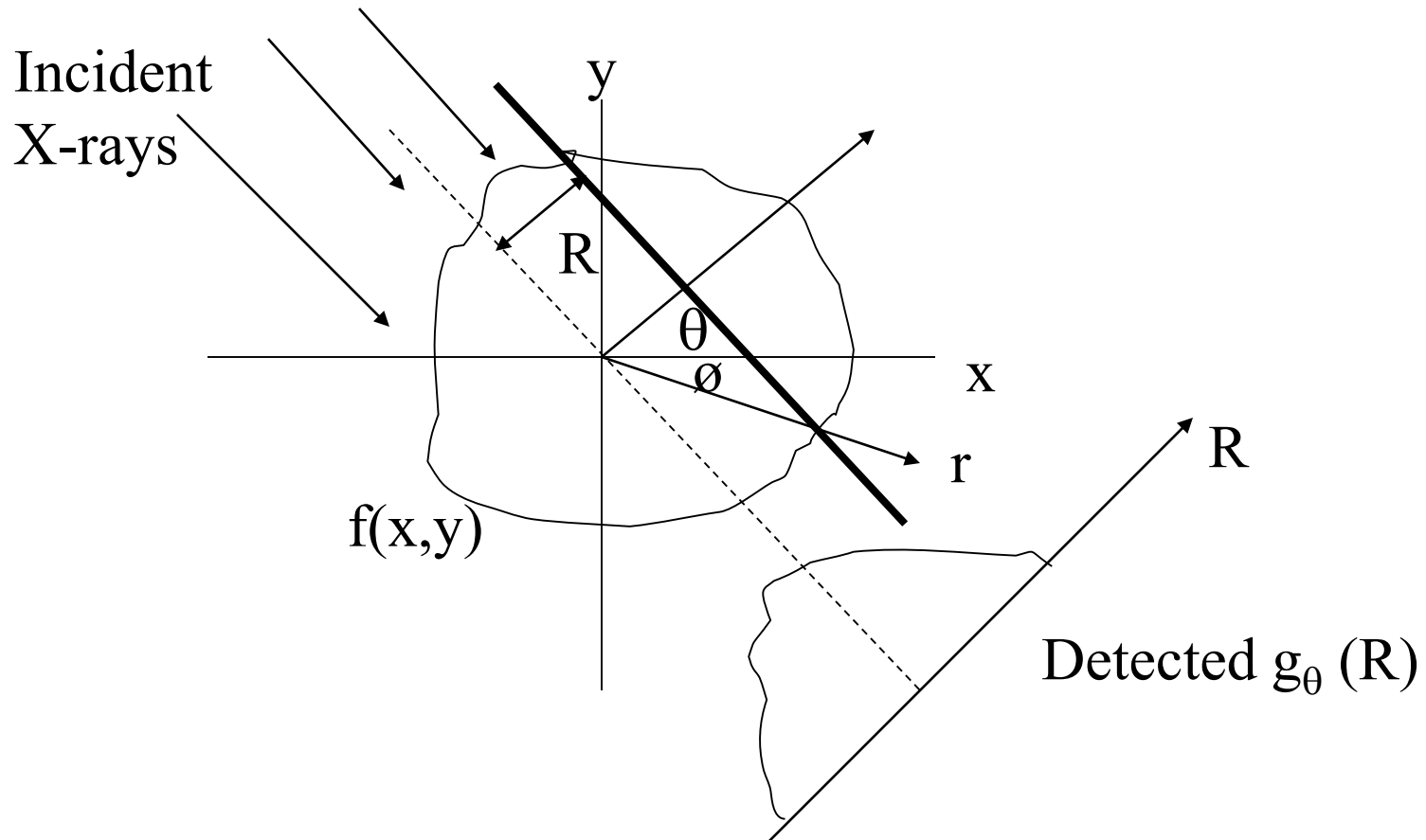

1D Fourier Transforms of all projections at angles $\theta=1-360$ forms a 2D Fourier space of the image.

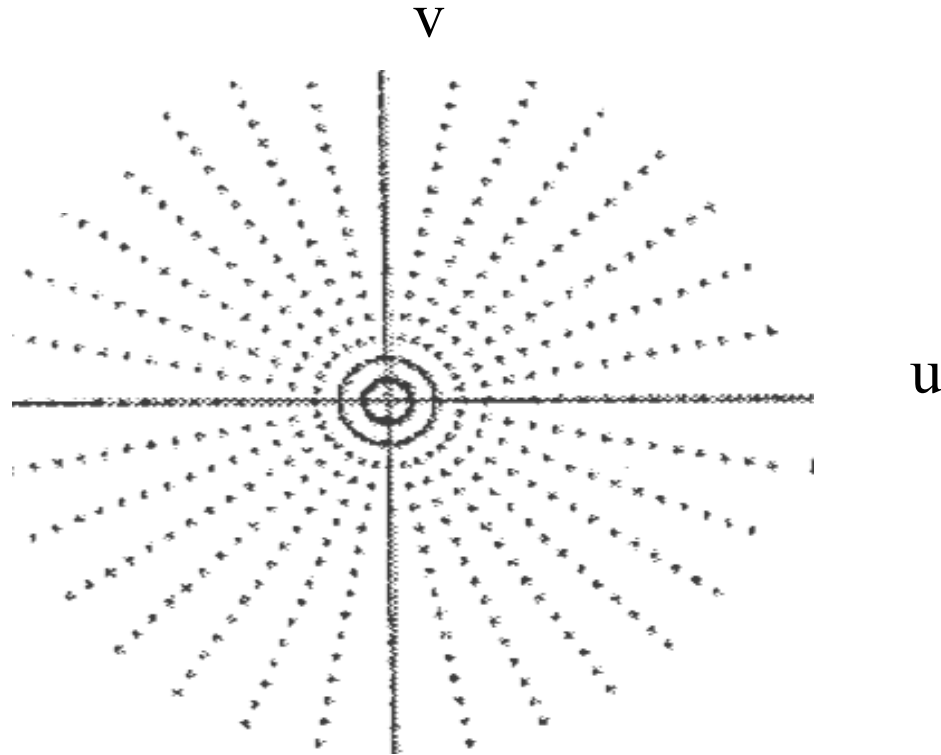

$$F(u,v)$$

The projection $g_\theta (R)$ can thus be calculated as a set of line integrals, each at a unique R .

$$g_\theta (R) = \iint f(x,y) \delta (x \cos \theta + y \sin \theta - R) dx dy$$

$$g_\theta (R) = \int_0^{2\pi} \int_0^\infty f(r, \phi) \delta (r \cos (\theta - \phi) - R) r dr d\phi$$

In the second equation, we have translated to polar coordinates.

Again $g_\theta (R)$ is a 1D function of R .

CT SNR

In CT, the recon algorithm calculates the $\bar{\mu}$ of each pixel.

$$x\text{-ray} = N_0 e^{-\int \mu dz}$$

recorder intensity

For each point along a projection $g_\theta(R)$, the detector calculates a line integral.

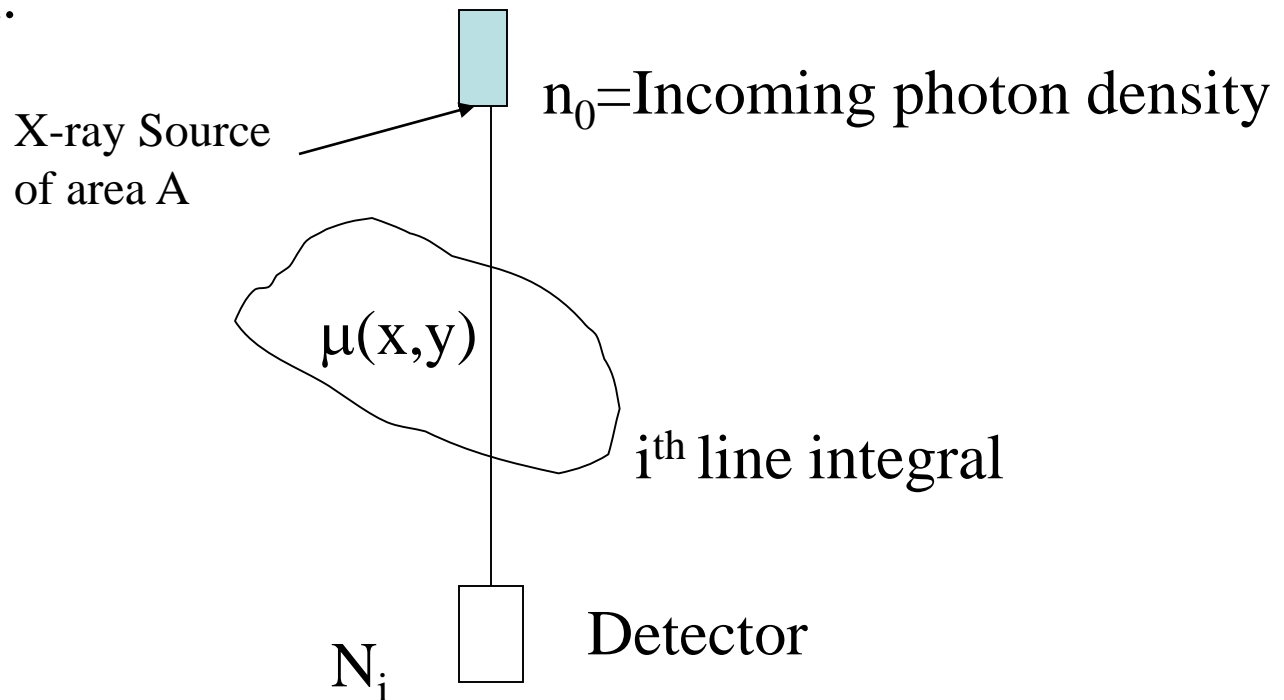

$$N_i = n_0 A \exp \int_i -\mu \, dl = N_0 \exp \int_i -\mu \, dl$$

$$N_0 = n_0 A$$

where A is area of detector and

The calculated line integral is $\int_i \mu \, dl = \ln (N_0/N_i)$

$$\text{Mean} = \bar{\mu} \approx \ln (N_0/N_i)$$

$$\sigma^2(\text{measured variance}) \approx 1/N_i$$

Now we use these line integrals to form the projections $g_\theta(R)$. These projections are processed with convolution back projection to make the image.

$$\text{SNR} = C \bar{\mu} / \sigma_\mu$$

Discrete Backprojection over M projections

$$\bar{\mu}(x,y) = \sum_{i=1}^M g_{\theta}(\mathbf{R}) * c(\mathbf{R}) * \delta(\mathbf{R}-\mathbf{R}') \Delta\theta$$

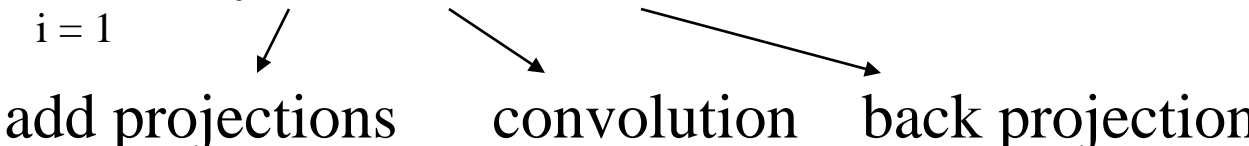
add projections convolution back projection

Where:

$$\mathbf{R}' = r \cos(\theta - \phi)$$

$$\Delta\theta = \pi/M \quad (\text{usually})$$

$$\Rightarrow \quad \bar{\mu} = M/\pi \int_0^{\pi} g_{\theta}(\mathbf{R}) * c(\mathbf{R}) * \delta(\mathbf{R}-\mathbf{R}') d\theta$$

Recall $\mu = M/\pi \int g_\theta(\mathbf{R}) * c(\mathbf{R}) * \delta(\mathbf{R}-\mathbf{R}') d\theta$

$H(u) = (M/\pi) (C(v) / |v|)$ is system impulse response of CT system

$C(v)$ is the convolution filter that compensates for the $1/|v|$ weighting from the back projection operation

Let's get a gain (DC) of 1. Find a $C(v)$ to do this.

We can consider $C(v) = |v| a \text{rect}(v/ 2v_0)$.

Find constant a

If we set $H(0) = 1$, DC gain is 1.

$$H(0) = (M/\pi) a \Rightarrow a = \pi/M$$

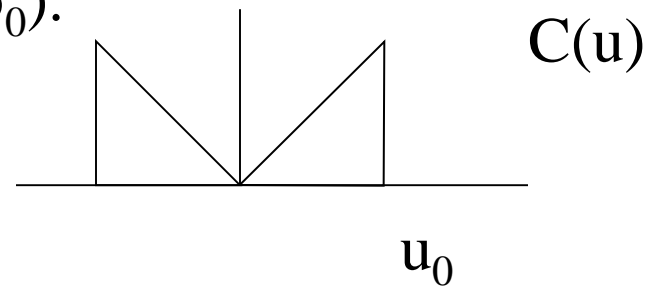

Therefore, $C(u) = (\pi/M) |v| \text{rect}(\pi/ 2\rho_0)$.

This makes sense – if we increase the number of angles M , we should attenuate the filter gain to get the same gain.

At this point, we have selected a filter for the convolution-back projection algorithm. It will not change the mean value of the CT image. So we just have to study the noise now.

The noise in each line integral is due to differing numbers of photons. The processes creating the difference are independent.

- different section of the tube, body paths, detector

Recall

$$\mu = M/\pi \int_0^\pi g_\theta(\mathbf{R}) * c(\mathbf{R}) * \delta(\mathbf{R}-\mathbf{R}') d\theta$$

convolution

Then the variance at any pixel

$$\sigma_\mu^2 = M/\pi \int_0^\pi \sigma_g^2(\mathbf{R}) \delta(\mathbf{R}) * [c^2(\mathbf{R})] d\theta$$

variance of any one detector measurement

Assume $\sigma_g^2 = \frac{1}{\bar{n}h}$ with \bar{n} = average number of transmitted photons per unit beam width and h = width of beam

$$\sigma_{\mu}^2 = (M/\pi) (1/(\bar{n}h)) \int_0^{\pi} d\theta \int c^2(R) dR = M/\bar{n}h \int c^2(R) dR$$

Easier to evaluate in frequency domain. Using Parseval's Rule

$$\sigma_{\mu}^2 = M/(\bar{n}h) \int_{-\infty}^{\infty} |C(u)|^2 du = \frac{M}{\bar{n}h} \int_{-u_0}^{u_0} u^2 \frac{\pi^2}{M^2} du$$

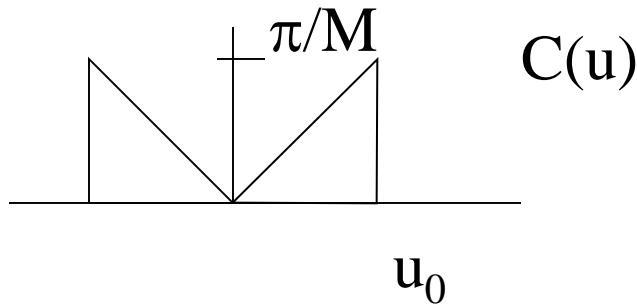

$$\sigma_{\mu}^2 = \frac{\pi^2}{\bar{n}hM} \frac{2u_0^3}{3}$$

$$SNR = C \frac{\bar{\mu}}{\sigma_{\mu}} = \frac{C\bar{\mu}\sqrt{3/2\bar{n}hM}}{\pi} u_0^{-3/2}$$

The cutoff for our filter $C(\nu)$ will be matched to the detector width w .

Let's let $u_0 = K/w$ where K is a constant

$$SNR = K' C \mu \sqrt{\bar{n} h M} w^{3/2}$$



Combine all the constants

\bar{n} was defined over a continuous projection

Let $\bar{N} = \bar{n}A = \bar{n}wh =$ average number of photons per detector element.

$$SNR = K' C \mu \sqrt{\bar{N} M} w$$

In X-ray, $SNR \propto \sqrt{\bar{N}}$

For CT, there is an additional penalty. To see this, cut w in $1/2$.
What happens to SNR?

Why \Rightarrow Due to convolution operation